

Deutsch Connectors:

"A" DTM06-12SA (CON70389) + WM-12S (CON70391) + 12x0462-201-20141 (CON70216/5) + DTM12S-BT (CON70914)
 "B" DTM06-12SB (CON70390) + WM-12S (CON70391) + 12x0462-201-20141 (CON70216/5) + DTM12S-BT-BK (CON70913)

Deutsch Accessories:

Pin Extractor: SRK-RT-01
 Crimping Tool: HDT-48-00

Case: CON70914

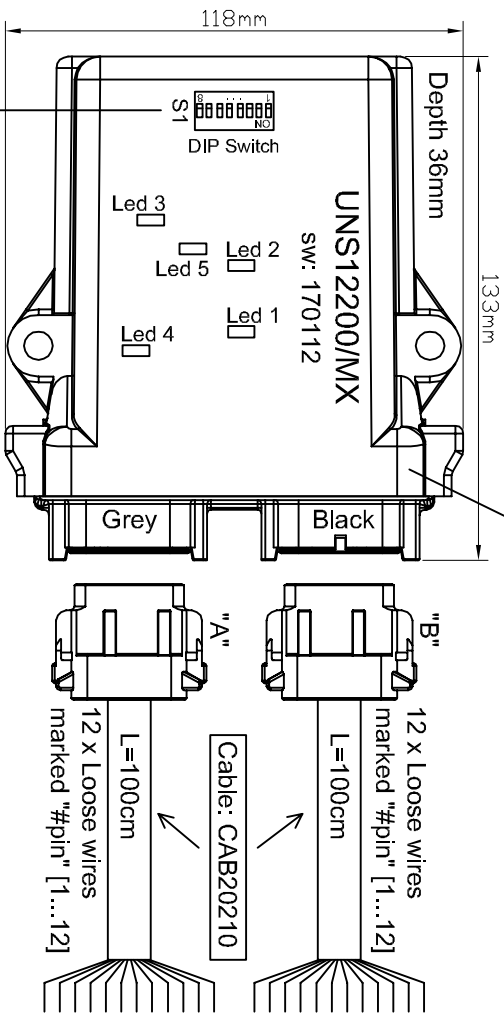

External connections

Connector "A" (DTM06-12SA - Grey)

- 1: Power supply (12...24Vdc)
- 2: GND
- 3: Low Oil Press (***)
- 4: Over Temperature (switch active when closed to gnd)
- 5: Battery Voltage 1 (0...32.6V)
- 6: Not Connected (NC)
- 7: Not Connected (NC)
- 8: NMEA 2000 NET-H (CAN+H)
- 9: NMEA 2000 NET-L (CANL)
- 10: NMEA 2000 NET-C (power supply V-)
- 11: Not Connected (NC)
- 12: Not Connected (NC)

Connector "B" (DTM06-12SB - Black)

- 1: Not Connected (NC)
- 2: GND
- 3: Engine Speed (0..10000Hz = 0...16000rpm) (*)
- 4: Not Connected (NC)
- 5: Battery Voltage 3 (0...32.6V)
- 6: Not Connected (NC)
- 7: Engine Water Temp Input (287..220 = 40..120°C)
- 8: Engine Oil Press Input (10..1800 = 0..10bar)
- 9: Fuel Level % Input (10..1800 = 0..100%)
- 10: Rudder Angle Input (10..95..1800 = +40.0..-40°) (*) (**)
- 11: Low Sys Volt Sel (Open: V1_T=8V - GND: V1_T=16V)
- 12: Not Connected (NC)

(***) switch active when closed to gnd and alarm enabled when engine is running (rpm>300rpm and t>10s)

(*) with Gain Adj
 (**) with Offset Adj

INTERNAL DIAGNOSTIC LED:

- Led 1 (green): SVP - ON => OK
- Led 2 (green): 3V3P - ON => OK
- Led 3 (green): CPU - If Main Running => blinking with T_OR=1s + T_Off=1s. Otherwise failure => ON (and also during the PowerOn) or OFF.
- Led 4 (green): FAULT - ON => Cumulative Fault
- Led 5 (green): CanBus Status - ON: message transmission or reception.

Dip	Function
1	Always OFF - ON = Rudder calibration input: Zero Increases
2	Always OFF - ON = Rudder calibration input: Zero Decrease
3	Always OFF - ON = Rudder calibration input: Gain Increases
4	Always OFF - ON = Rudder calibration input: Gain Decrease
5	Always OFF - ON = Engine Speed calibration input: Gain Increase
6	Always OFF - ON = Engine Speed calibration input: Gain decrease
7	OFF => ID=0 - ON => ID=1 for Engine Instance NMEA2000
8	OFF => ID=0 - ON => ID=1 for Device Instance NMEA2000

Personalizzazione S1 di default:

- Dip 1 = OFF
- Dip 2 = OFF
- Dip 3 = OFF
- Dip 4 = OFF
- Dip 5 = OFF
- Dip 6 = OFF
- Dip 7 = OFF
- Dip 8 = OFF

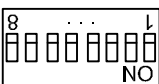

Pin-out NMEA2000 - M12 connector

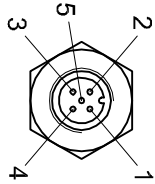

M12 Male Connector
 5 Pins male

Pin	NMEA2000 Function
1	Shield
2	NET-S (+V Supply)
3	NET-C (-V Supply) - Pin 10 Connector "A"
4	NET-H (CAN+H) - Pin 8 Connector "A"
5	NET-L (CANL) - Pin 9 Connector "A"

Pin transmitted on the NMEA 2000 Bus:

Engine Temperature	127489	(0x1f201)
Engine Oil Pressure	127489	(0x1f201)
Fuel Level Percent	127505	(0x1f211)
Rudder Angle	127245	(0x1f10d)
Engine Speed	127488	(0x1f200)
Battery Voltage 1	127508	(0x1f214)
Battery Voltage 3	127508	(0x1f214)
Low Oil Pressure	127489	(0x1f201)
Over Temperature	127489	(0x1f201)
Low System Voltage	127489	(0x1f201)

Rev: Date: Descrizione modifiche - Description of changes:

0	12/01/17	Prima emissione
1	15/02/19	Modifica descrizione funzione Dip-Switch 7-8
2	25/01/20	Inserimento pinout connettore M12-5pin

SAN GIORGIO S.E.I.N. GENOVA - ITALY

Tel. 010-8301222 - www.sanorgioseiln.com

Writing diagram NMEA2000 Converter - UNS12200/MX

Number:	Sheet:	Date:	Size:
D170113	1/1	25/01/20	A4

Completed: Silvestri M. Checked: Casaretto G. Approved: Manuelli M.

Se non diversamente specificato, tutte le dimensioni sono da intendersi in mm e le tolleranze delle quote ±0.1mm