

Class B AIS Transponder for Pleasure & Fishing Boats

SHIP A
Ship type : Other
Status : Underway
Speed / Course : 6.9kn / 275°
Length x Breadth : 22m x 8m
Draught : 0m

SHIP B
Ship type : Tug
Status : Underway
Speed / Course : 12.7kn / 310°
Length x Breadth : 42m x 9m
Draught : 2m

SHIP C
Ship type : Tug
Status : Underway
Speed / Course : 12.7kn / 310°
Length x Breadth : 164m x 26m
Draught : 5m

SHIP G
Ship type : Fishing
Status : Underway
Speed / Course : 7.7kn / 272°
Length x Breadth : 20m x 8m
Draught : 0m

SHIP D
Ship type : Pleasure Craft
Status : Underway
Speed / Course : 8.2kn / 115°
Length x Breadth : 20m x 6m
Draught : 0m

SHIP E
Ship type : Other
Status : Underway
Speed / Course : 13kn / 245°
Length x Breadth : 181m x 28m
Draught : 9.3m

SHIP F
Ship type : Cargo
Status : Underway
Speed / Course : 9.9kn / 267°
Length x Breadth : 20m x 16m
Draught : 5.8m



Real-time Vessel Traffic Information.

All the Advantages of AIS Transponder in an Easy to Use, Compact Design

What is an AIS transponder?

An AIS transponder on your boat automatically receives information broadcast by other AIS-equipped vessels and base stations, all while your own vessel's static and dynamic information is being transmitted. AIS signals may reach where radar cannot, showing AIS-equipped vessels that might otherwise be hidden, such as on the other side of an island or behind a larger vessel. SOLAS commercial vessels are already required to carry a Class A AIS transponder, so your position will be known by nearby large vessels. The MA-500TR increases your safety at sea.

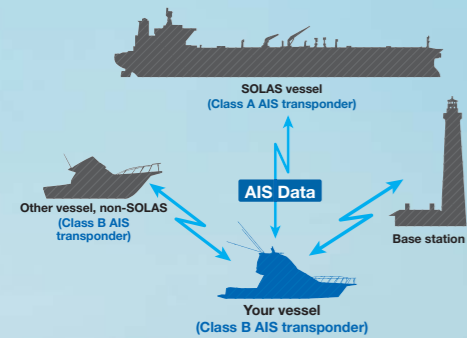

Class B AIS transponder

The MA-500TR is a Class B AIS transponder for Non-SOLAS vessels such as pleasure craft, work-boat and small vessels. Your vessels information will automatically be transmitted at fixed intervals or under base station control. The MA-500TR receives dual AIS channels (Ch. 87B and Ch. 88B) simultaneously and receives both Class A and Class B AIS information.

Transmitted information by MA-500TR is

- MMSI code
- Vessel name
- Call sign
- Type of ship
- GPS antenna position
- Ship's position
- SOG (Speed over ground)
- COG (Course over ground)
- UTC date and time
- GPS antenna type
- PA (Position Accuracy)

Simple operation

The Plotter display looks like a marine radar display. North-up, course-up and range zoom from 0.125 NM to 24 NM are supported. The Target list display shows all detected AIS equipped vessels and targets. The Danger list display shows a list of vessels that are within 6 NM CPA and 60 minutes TCPA from your vessel. The Danger list can be sorted by CPA or TCPA order. In addition to these display types, the Detail screen shows various information about the selected AIS target.

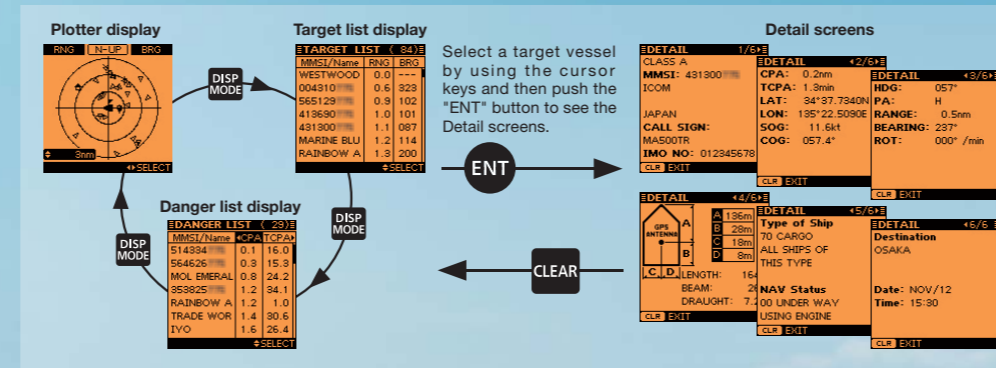

CPA and TCPA for collision-risk management

When a vessel comes into the CPA and TCPA range, the vessel icon blinks on the Plotter display and emits a beep sound. When connected to external audio equipment installed on the deck or tower, the collision alarm function will alert you even when you are away from the AIS transponder.



Individual DSC call*

When connected to a compatible Icom VHF radio, it's easy to make an individual DSC call. Select a vessel using the MA-500TR's cursor keys and then push the "DSC" button on the MA-500TR. It is not required to input an MMSI number manually.



*This function works only when connected to compatible Icom transceivers.

100 Waypoints memory

Up to 100 waypoints can be stored on the waypoint list. The "MOB" button allows you to set a waypoint on your current position instantly.

Safety-related message

When the MA-500TR receives a safety-related message from a Class A AIS transponder, the message icon appears on the Plotter display. Up to 20 received DSC messages are automatically stored in the log memory.

3-line NMEA input/output

The MA-500TR has 15-pin D-SUB connector providing 3-lines of NMEA input/output on the rear panel. The supplied NMEA connector cable simplifies the installation and connection to the VHF radio and other navigation equipment.

MXG-5000S GPS receiver

The GPS receiver, MXG-5000S comes with the MA-500TR*. It is a 66 channel parallel GPS receiver with SBAS function.



*The MXG-5000S may be sold separately, depending on version.

Other features

- Full dot-matrix display with adjustable backlight and contrast
- IPX7 waterproof protection (up to 1 m depth of water for 30 minutes; except connectors)
- Self diagnostics function
- Flush mount installation with optional MB-75
- Slow warn function

* VHF radio is sold separately. Above photo shows the IC-M506 (USA version). For Europe this is the IC-M506EURO.

CLASS B AIS TRANSPONDER
MA-500TR

SPECIFICATIONS

GENERAL

- Operating frequencies : 161.975, 162.025 MHz (Ch 87B, 88B, default) 156.025–162.025 MHz
- Type of emission : 16K0G3W (GMSK)
- Antenna impedance : 50 Ω
- Usable temperature range : -20°C to +60°C ; -4°F to +140°F
- Power supply requirement : 12 V DC (9.6–15.6 V)
- Current drain : TX 1.5 A (at 12.0 V DC) RX 0.7 A
- Dimensions (W × H × D): 165 × 110 × 123 mm (projections not included) ; 6.5 × 4.33 × 4.84 in
- Weight (approx.) : 1.0 kg; 2.2 lb

TRANSMITTER

- Output power : 2 W
- Modulation : GMSK
- Conducted spurious emission : Less than -36 dBm

RECEIVER

- Sensitivity (20% error rate) : -110 dBm (AIS/DSC)
- Adjacent Ch. selectivity : More than 70 dB (AIS/DSC)
- Spurious response : More than 70 dB (AIS) More than 70 dB (DSC)
- Intermodulation : More than 65 dB (AIS/DSC)
- Conducted spurious emission : Less than -57 dBm (AIS)

Measurements made in accordance with IEC 62287-1.

All stated specifications are subject to change without notice or obligation.

DATA INTERFACE

- Data Input Interface : NMEA1, NMEA3 IEC 61162-1: 2000 (4800 bps) or IEC 61162-2 (38400 bps) NMEA2 IEC 61162-2 (38400 bps)
- Sentence format : RMC, GGA, VTG, GSA, GSV, DTM, GNS, GLL, and GBS*1
- Input level (2 V applied) : Less than 2 mA
- Data Output Interface : NMEA1, NMEA3 IEC 61162-1: 2000 (4800 bps) or IEC 61162-2 (38400 bps) NMEA2 IEC 61162-2 (38400 bps)
- Sentence format : NMEA1 DSC, RMC, GGA, VTG, GSA, GSV, GBS, DTM, DSE, GNS and GLL NMEA2 VDM, VDO, ALR, ACA, ACS, TXT, RMC*2, GGA*2, GNS*2, GLL*2, VTG*2, GSA*2, GSV*2, GBS*2 and DTM*2 NMEA3 RMC, GGA, VTG, GSA, GSV, GBS, DTM, GNS, and GLL
- Output level : 5 V, 40 mA Max. RS-422 balanced type
- Rating of alert terminal : 24 V DC, 500 mA max.

*1 To use a third party GPS receiver with the MA-500TR, a GPS receiver with RAIM function is required.

*2 Depending on AIS output setting.

MA-500TR contents:

- AIS transponder, MA-500TR
- GPS receiver with 10m cable
- NMEA connector cable
- Mounting bracket kits
- DC power cable

DIMENSIONS

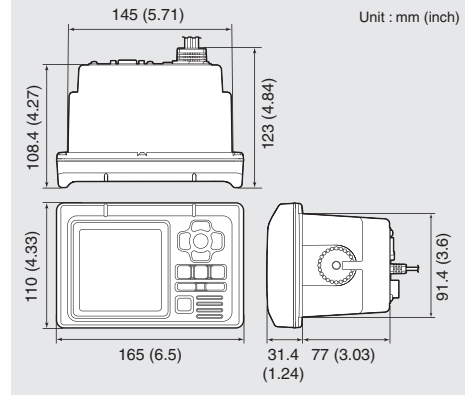

REAR PANEL VIEW

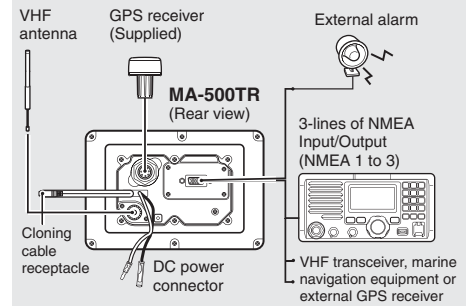

OPTIONS



MB-75 FLUSH MOUNT KIT

For flush-mounting the MA-500TR to a flat surface, such as a control panel.



• Shown with VHF radio (Sold separately).

Icom, Icom Inc. and the Icom logo are registered trademarks of Icom Incorporated (Japan) in Japan, the United States, the United Kingdom, Germany, France, Spain, Russia, Australia, New Zealand and/or other countries. All other trademarks are the properties of their respective holders.

Icom Inc. 1-1-32, Kamiminami, Hirano-Ku, Osaka 547-0003, Japan Phone: +81 (06) 6793 5302 Fax: +81 (06) 6793 0013

www.icom.co.jp/world

Count on us!

Your local distributor/dealer:



Advantec Srl

Via Caduti per la Libertà, 13
10060 Pinasca TO - Italy
Tel. +39 0121326770
info@advantec.it - www.advantec.it